



ENGINEERING LTD
 NUMBER ONE FOR PLANT HIRE
 OPERATED AND SELF DRIVE HIRE

Date: 31st January 2007

SAFETY BRIEFING

Lifting Eyes on Road/Rail Excavators

As a result of a change to the regulations on lifting eyes, all Case 988 and CX135 Road/Rail Excavators will have their existing lifting eyes replaced.

As an ongoing requirement, all operators MUST check the lifting eye for wear and distortion prior to the start of each shift with any defects reported to the company via the usual defect reporting system and logged in the blue F91 style logbook. You must check the following:

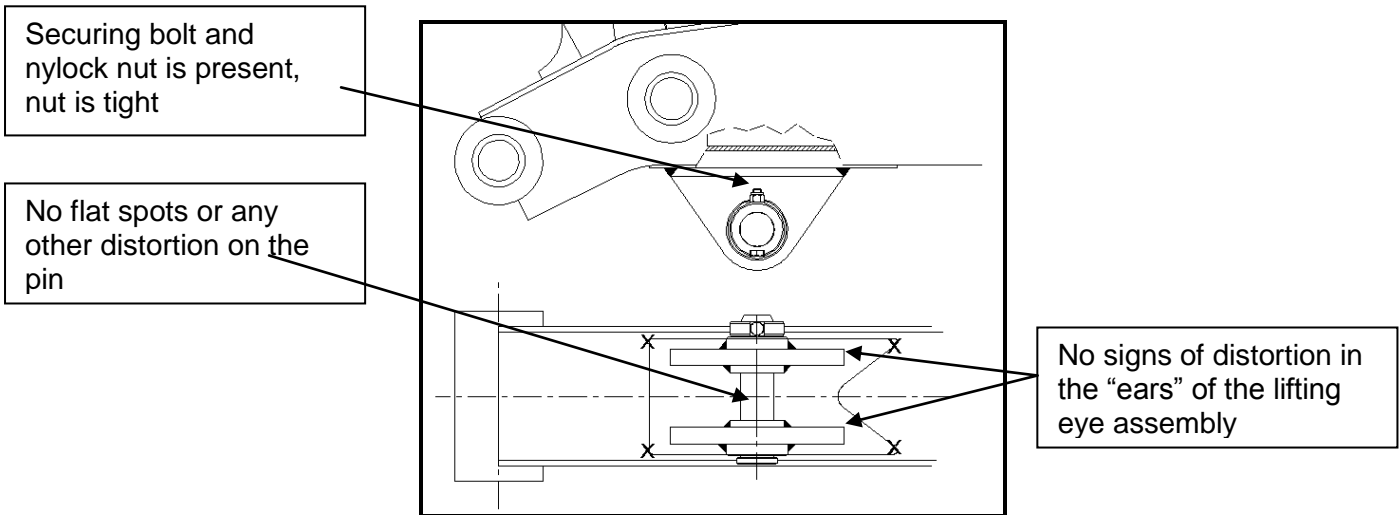

If the pin is required to be removed then the nylock nut must be tightened up afterwards firmly using the appropriate tools, not just finger tight.

Due to seriousness of this issue please send the overleaf acknowledgement slip back to your Rail Manager as soon as possible.

Andy Young
 SHEQ Director